



模組客製化 吉他流程

109034544 姜柏宏

109034545 蘇沛強

109034550 周宛昀

109034552 謝予欣

現況描述及問題分析

5W1H

01

改善成果

ER model,
Website, APP Demo

03

02

改善流程

AS-IS / TO-BE model
VSM, IDEF, FlexSim

04

結論及未來展望

01

現況描述及
問題分析

關於紅心吉他

2016年，台北

紅心吉他成軍，致力於打造屬於專業樂手的高階訂製木吉他品牌，從生產製造、樂器視覺設計到專屬技師，滿足專業樂手對於樂器的所有需求，從樂器開始建立樂手的個人風格。

“Rubyrave acoustic guitars are widely considered among the best-sounding and easiest to play in the world.”





採購成本

客製化所需之物料非批量進料，
願意配合之供應商較少

採購困難

訂製琴的零售價格大部分
超越新台幣80,000元

訂製價格



等候時間

平均訂製吉他所需等候時間，
自下單至琴主拿到琴約需要
半年以上的等候時間

許多獨立琴師有特殊的需求，
目前客製化還不普及
技術上難以配合顧客需求

顧客需求





WHAT

吉他製作等待時間長
為流程瓶頸



WHEN

製作吉他的時間



WHO

製琴師
想購買客製化吉他的顧客



WHERE

顧客在線上或到現場訂購
客製化吉他



WHY

等待耗時
無法預測顧客需求



HOW

As-Is、To-Be
線上資訊流

02

改善流程

As-Is v.s To-Be

As-Is

1. 訂製時間前置等待期長
2. 客製化吉他成本高、售價高
3. 非批量進料，採購困難
4. 製程需要因應客製化不同，作業困難

1. 訂製部分模組化，能延遲產品差異化
2. 因為物料選擇模組化，所以仍然可以
批量採購
3. 製程可以因應模組化，而固定製程，
作業較容易
4. 較類似Assembly to Order 的生產模式，
前置期大幅縮短

To-Be

As-Is_現況分析VSM

$$PCE = \frac{150}{350} = 0.482$$

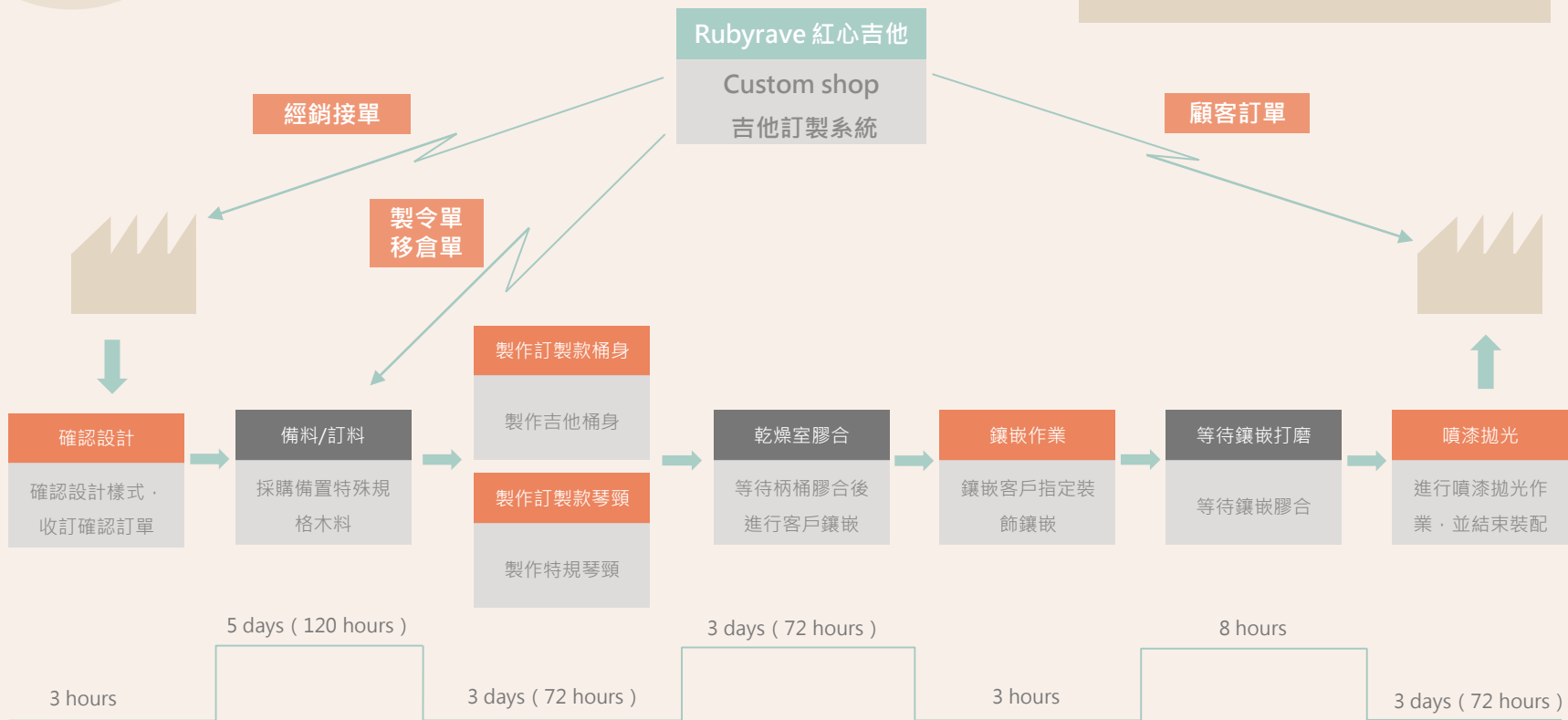

附加時間：150 (小時)

總時間：356 (小時)

IDEF A-0

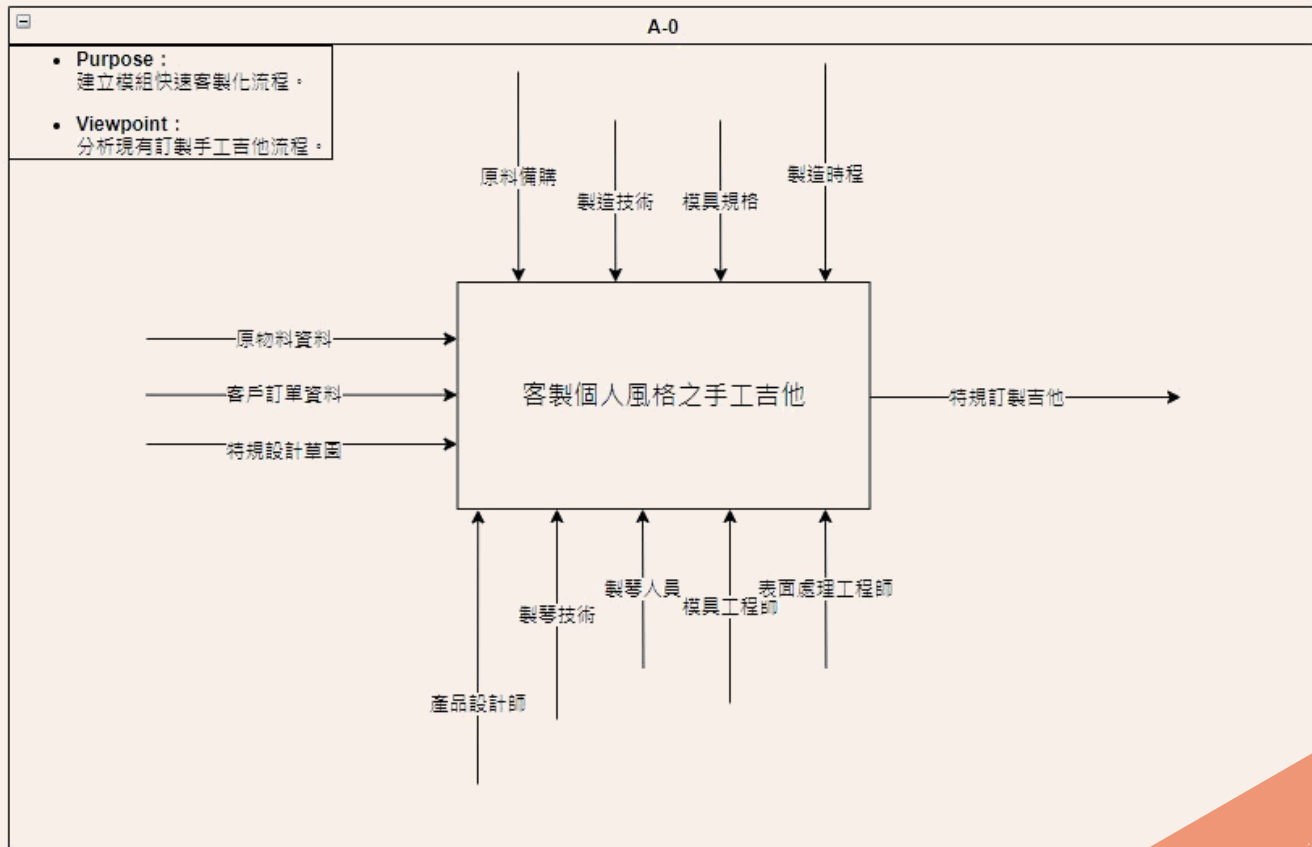

IDEF A0

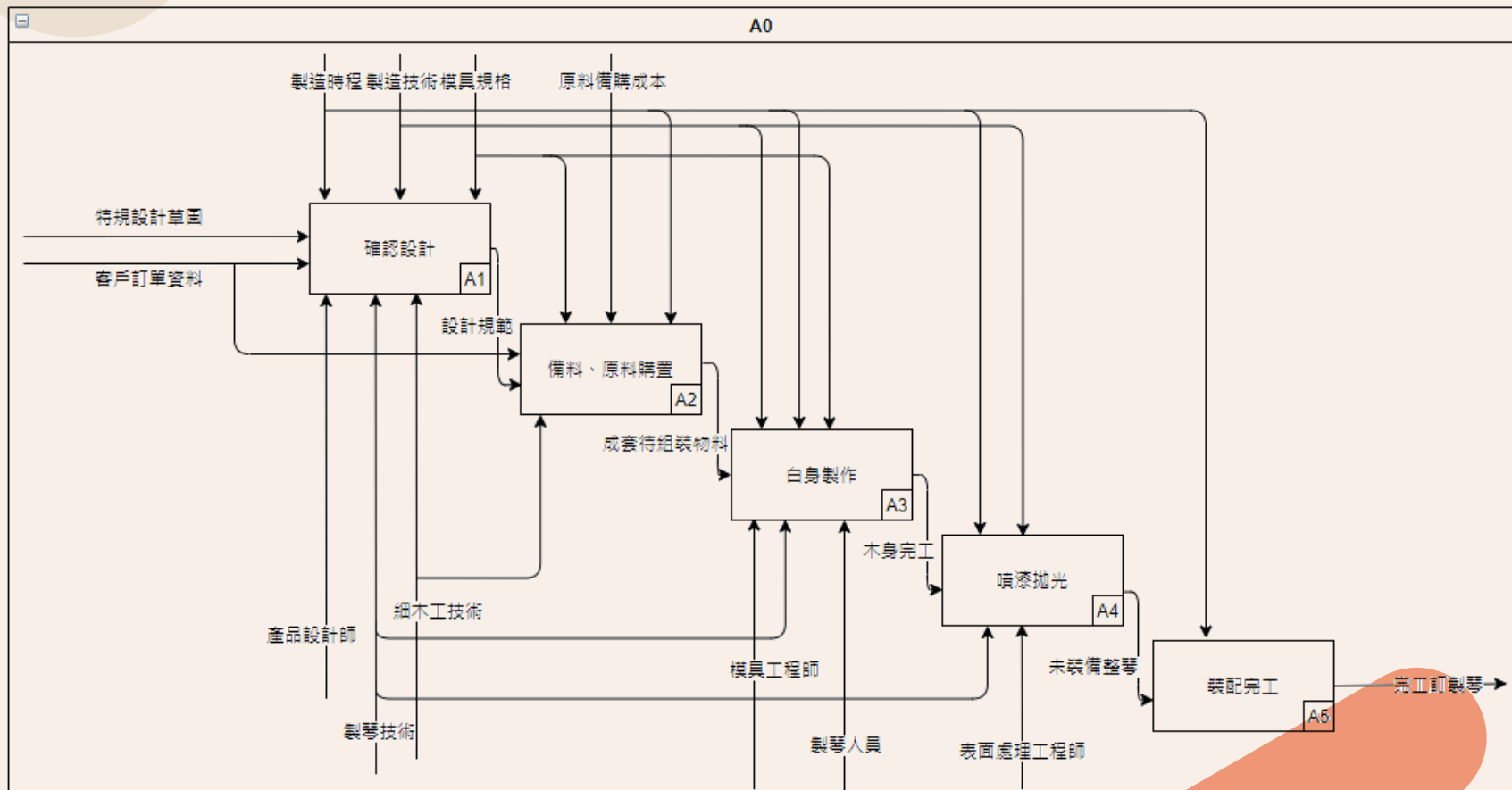

As-Is_IDEF A1

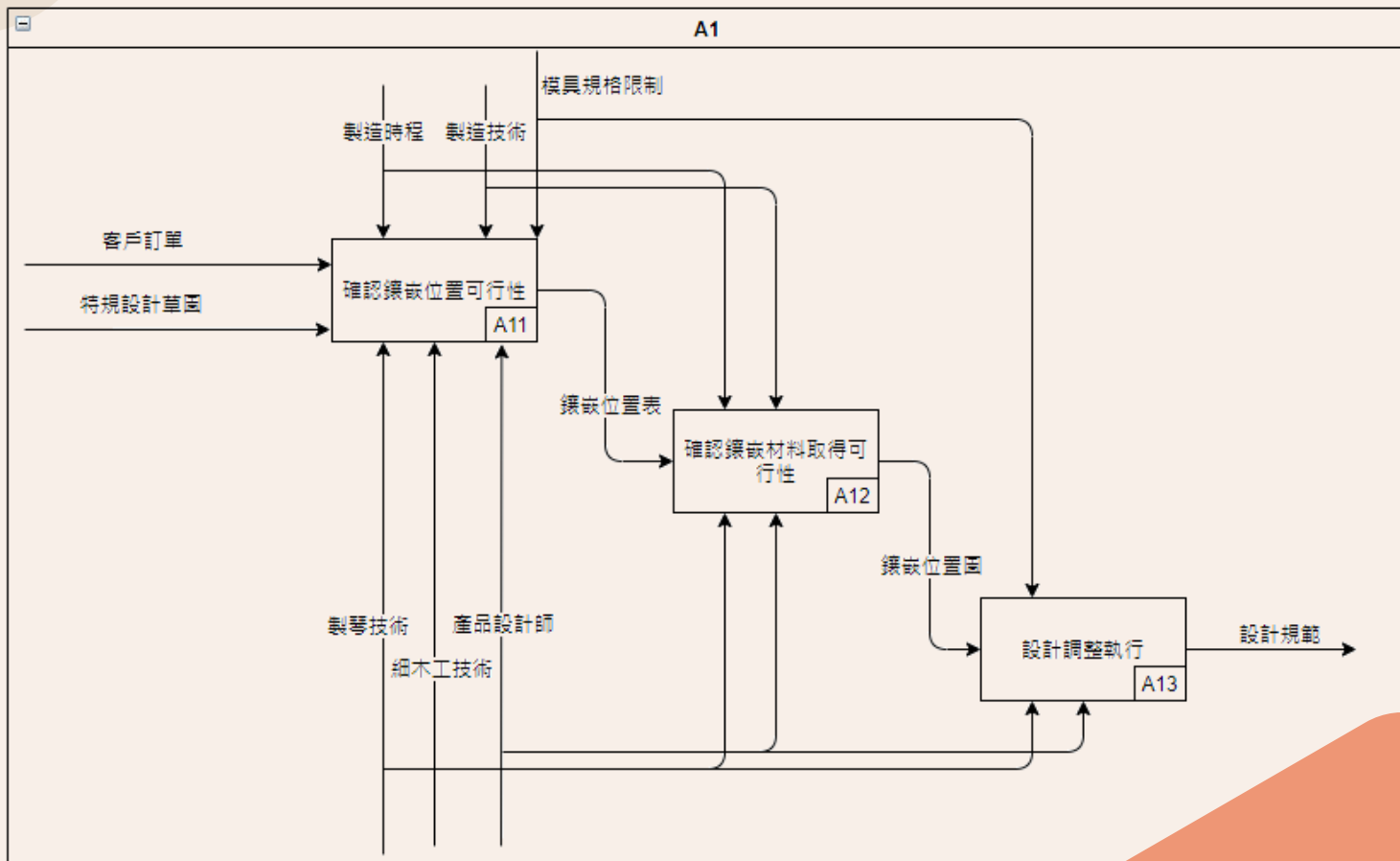

As-Is_IDEF A2

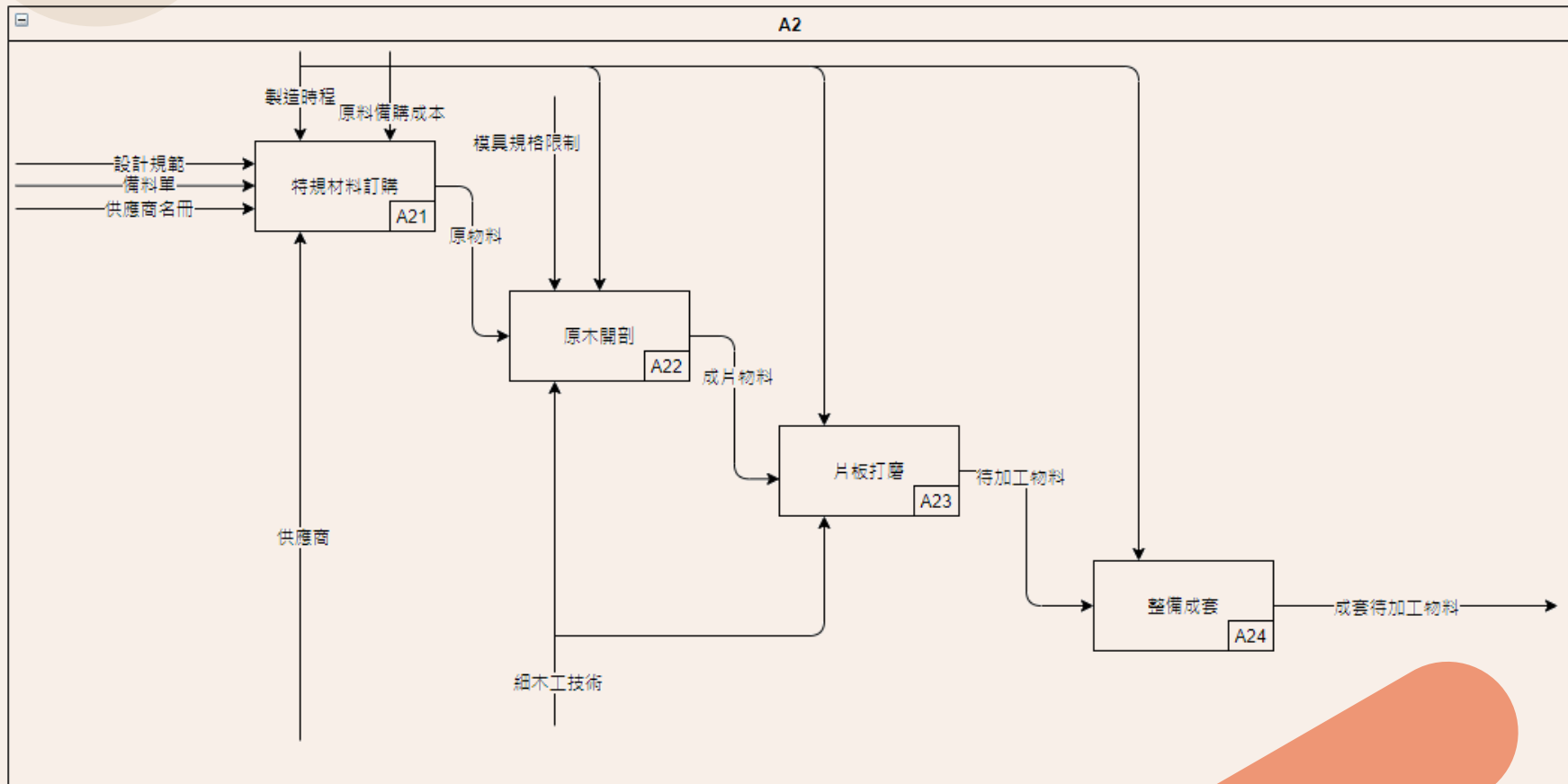

As-Is_IDEF A3

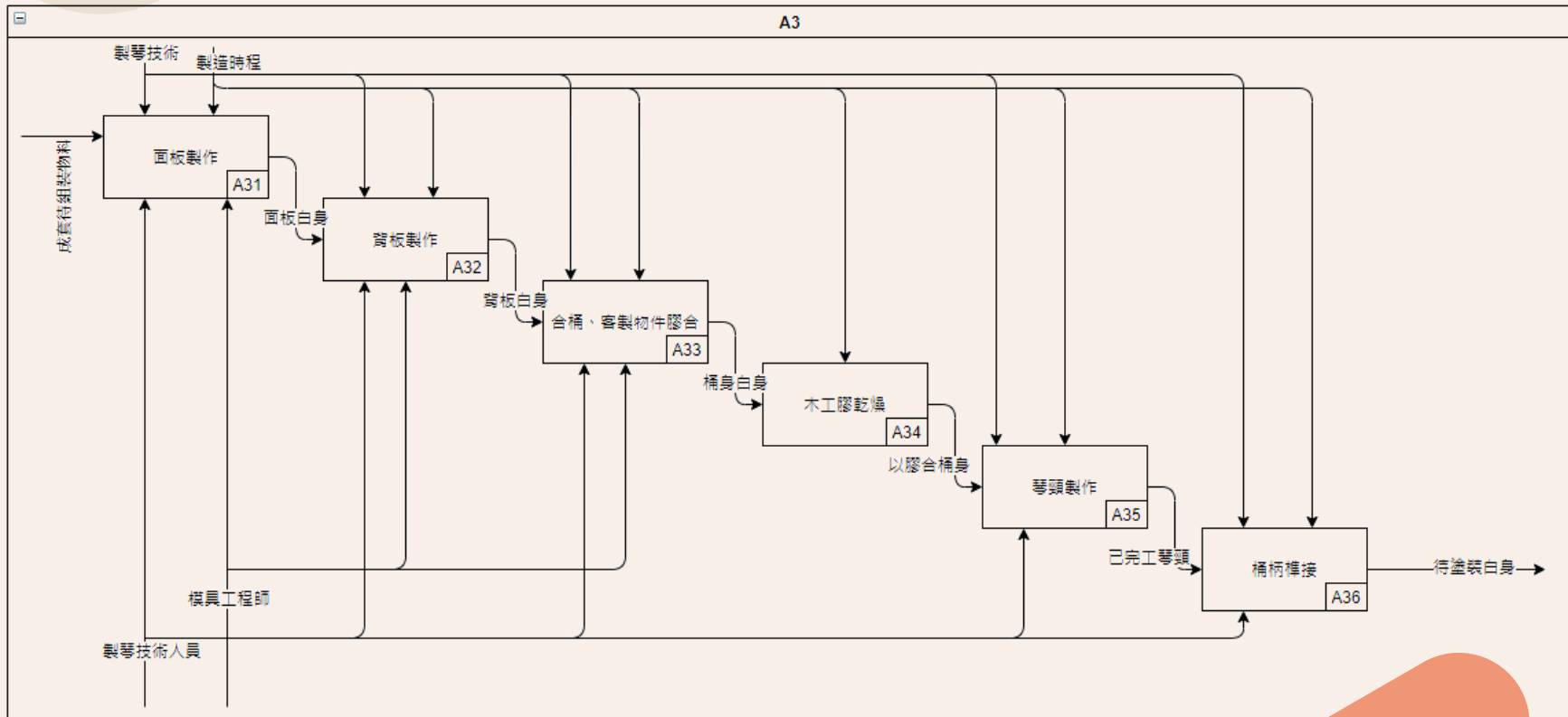

As-Is_IDEF A4

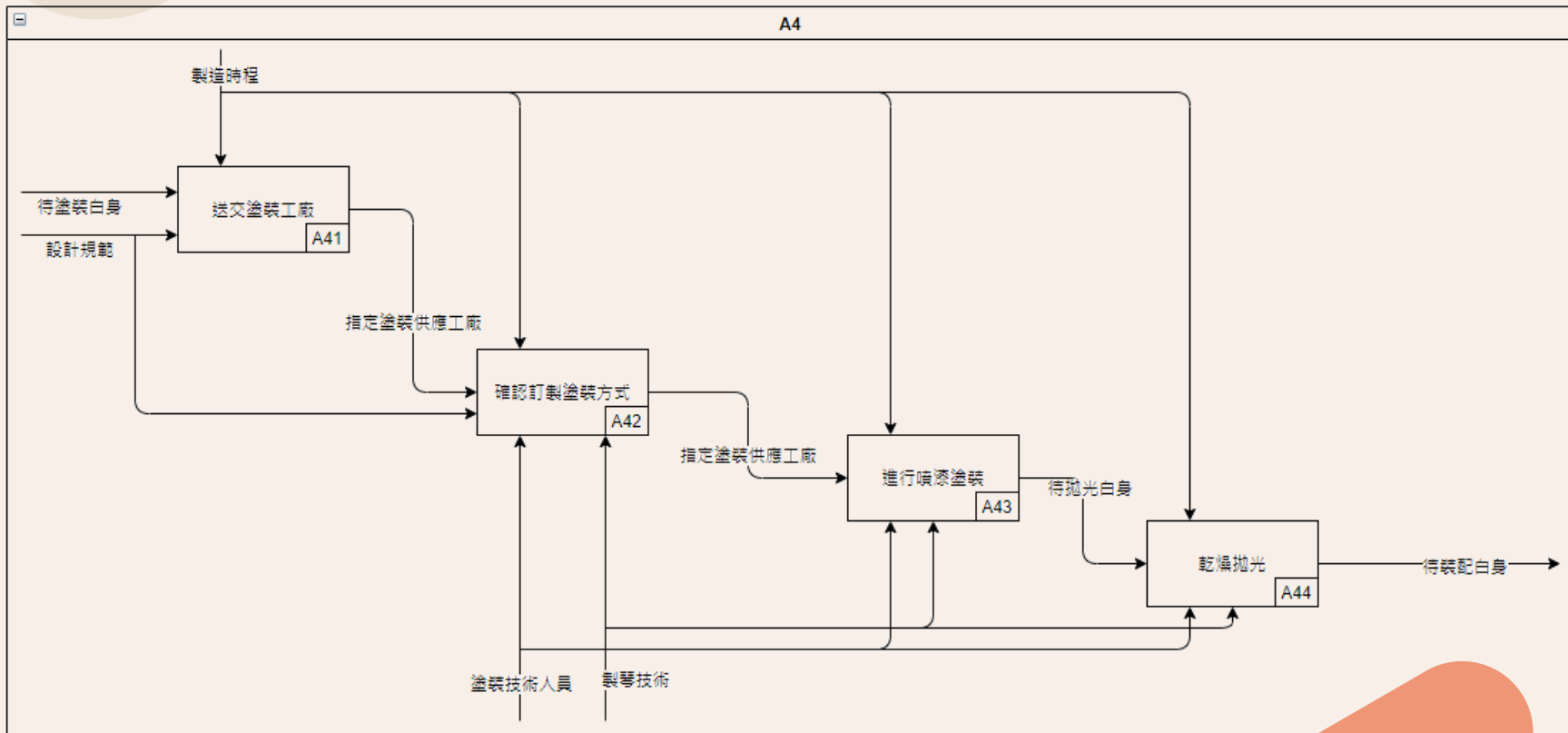

As-Is_Flexsim

Throughput Per 150 Days

Object	Throughput
Design confirm	60.00
Material Preparation	29.50
Body_ Neck building	29.50
Drying and Glueing	29.00
Inlay Process	29.00
Waiting sanding	29.00
Finish and Polish	29.00

Utilization

■ Idle ■ Processing

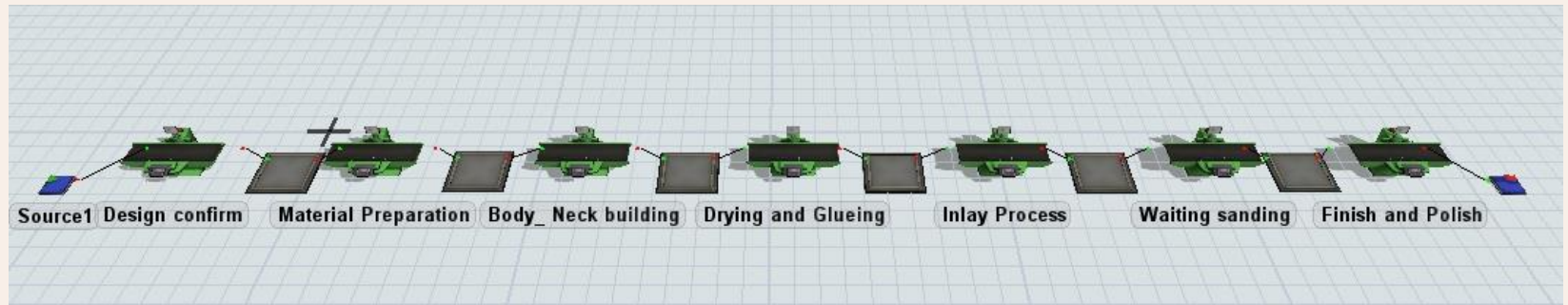
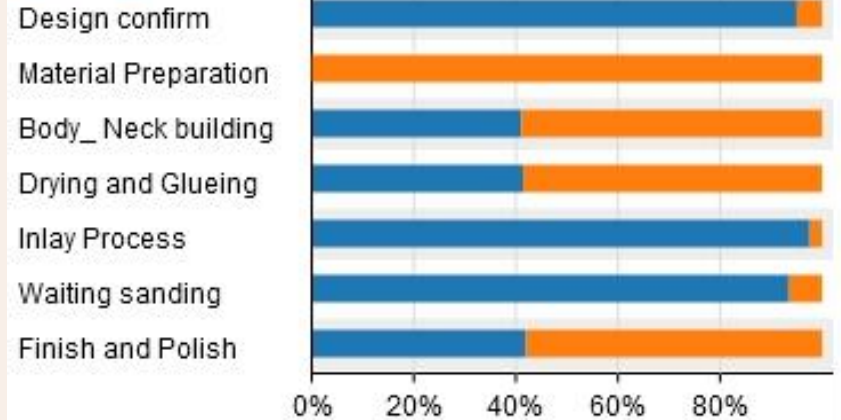

To-Be_目標模型VSM

$$PCE = \frac{121}{205} = 0.591$$

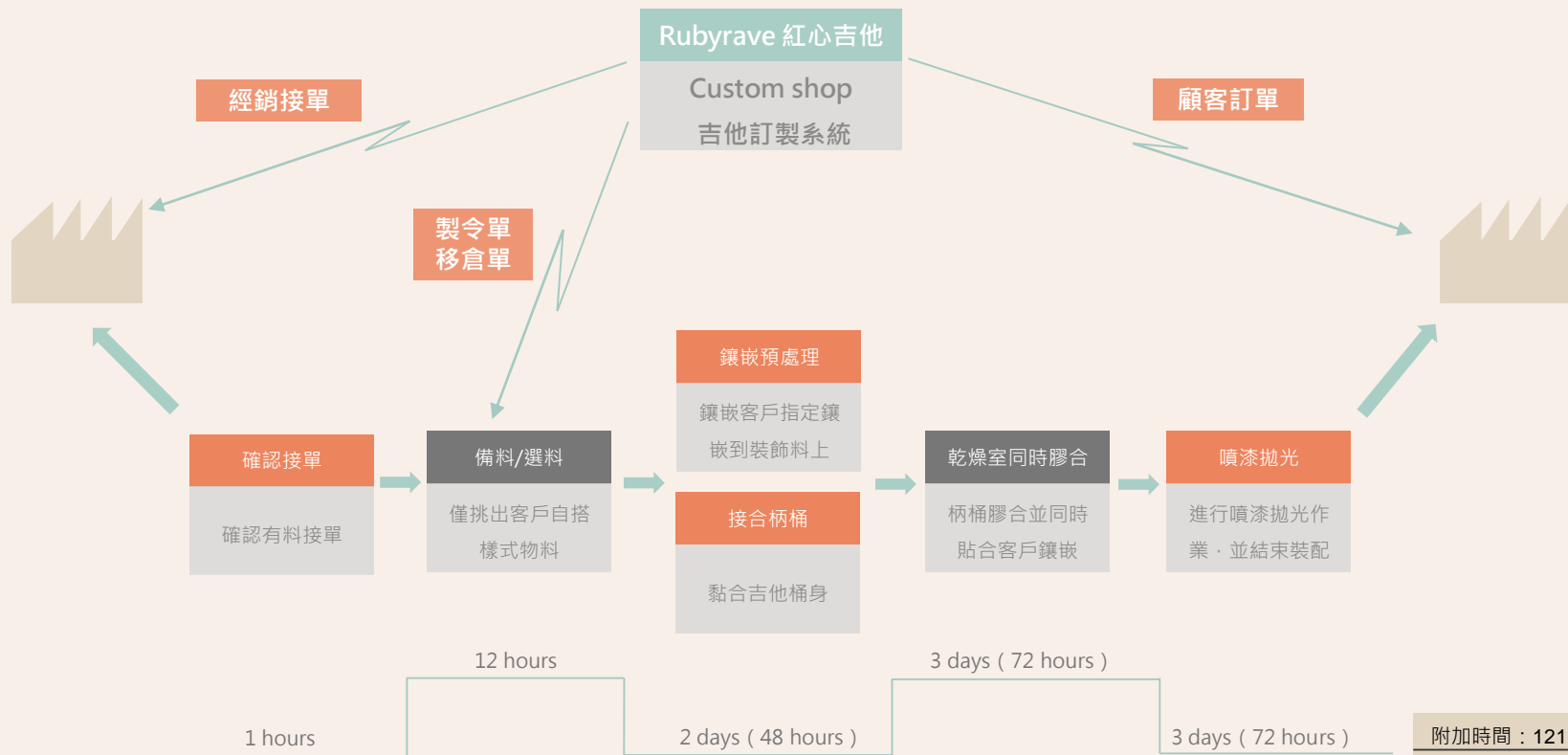

To-Be_ IDEF A1

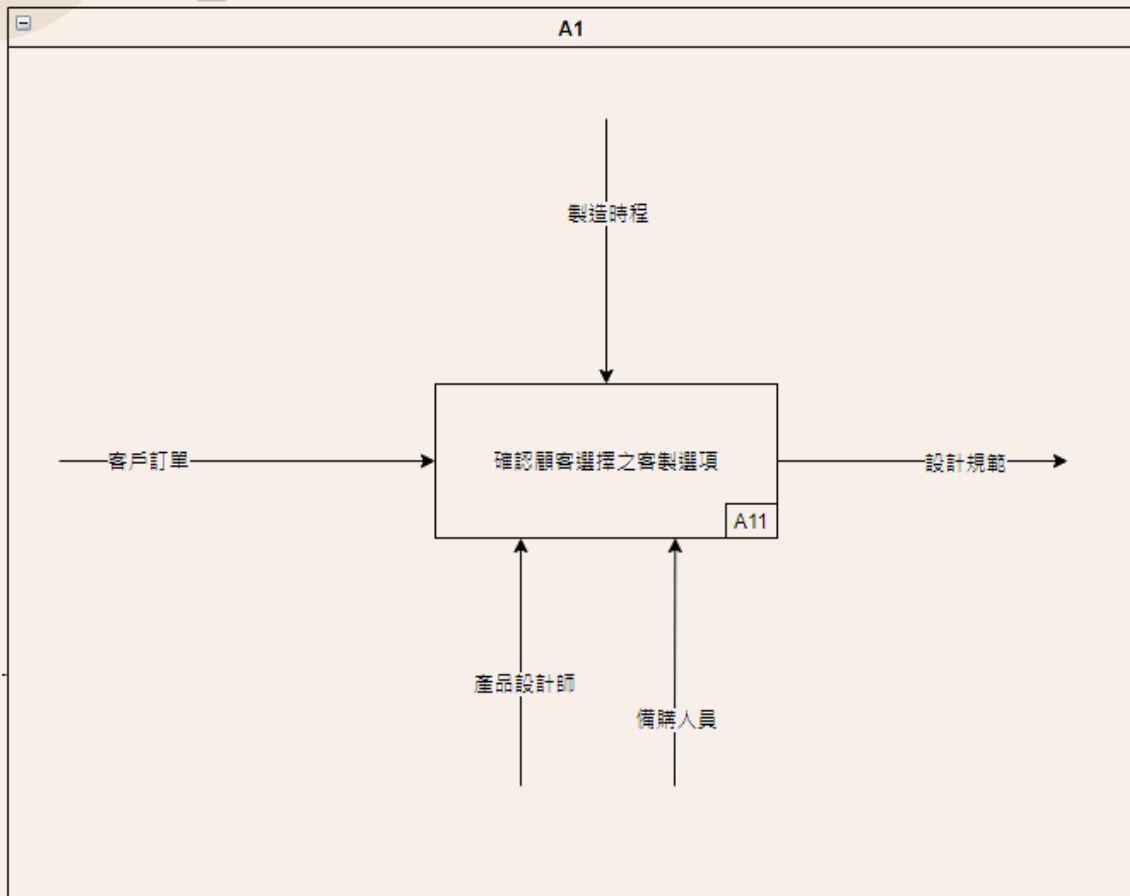

To-Be_ IDEF A2

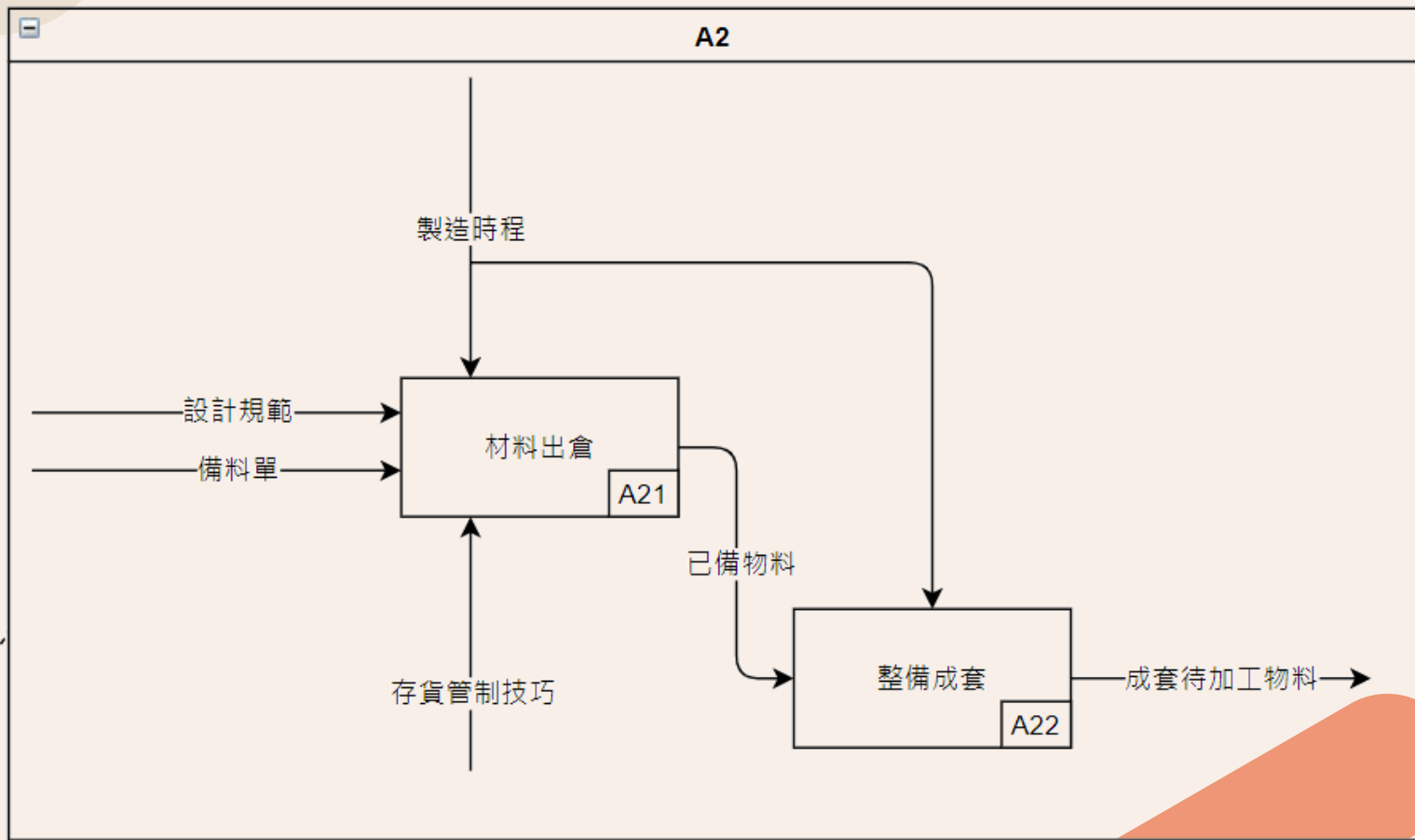

To-Be_ IDEF A3

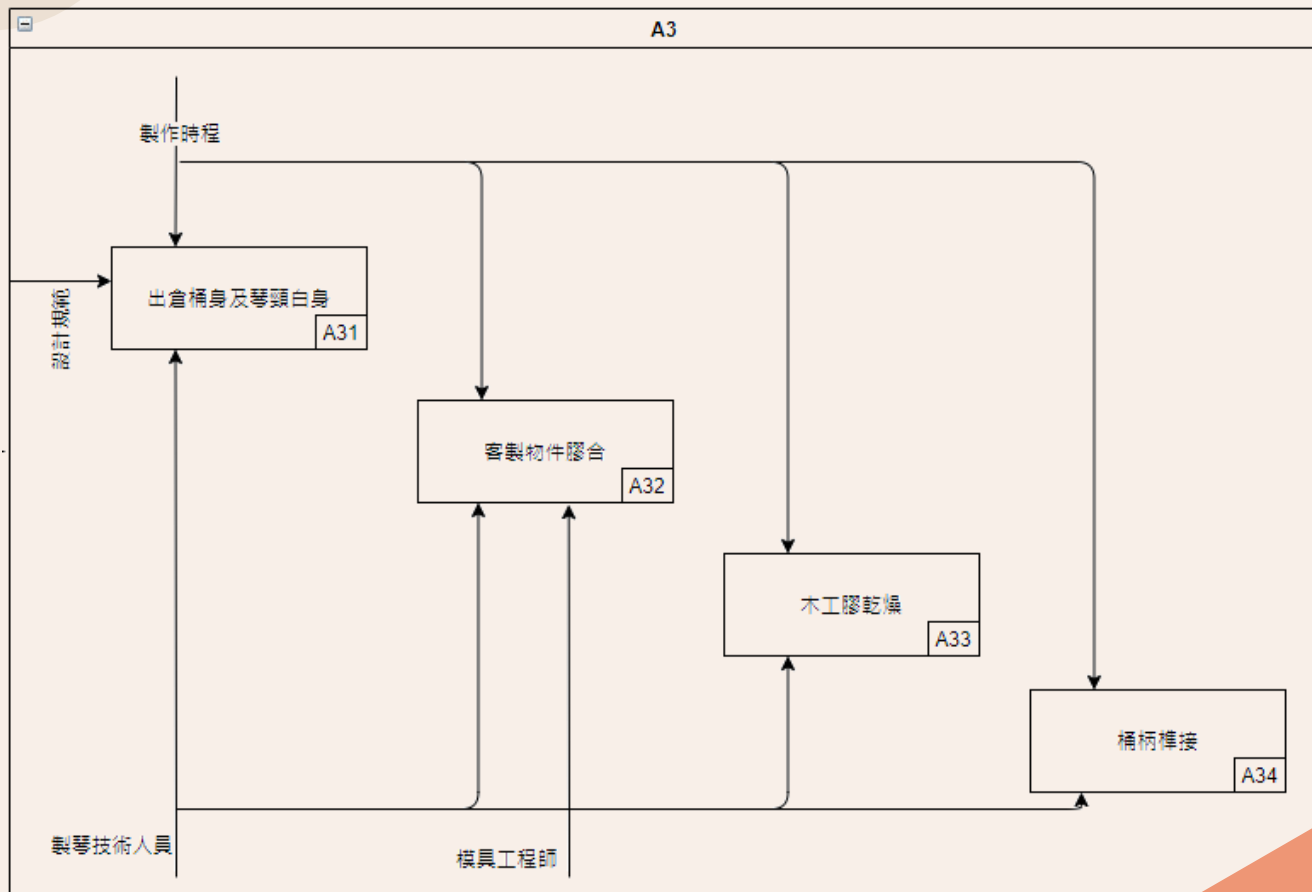

To-Be_ IDEF A4

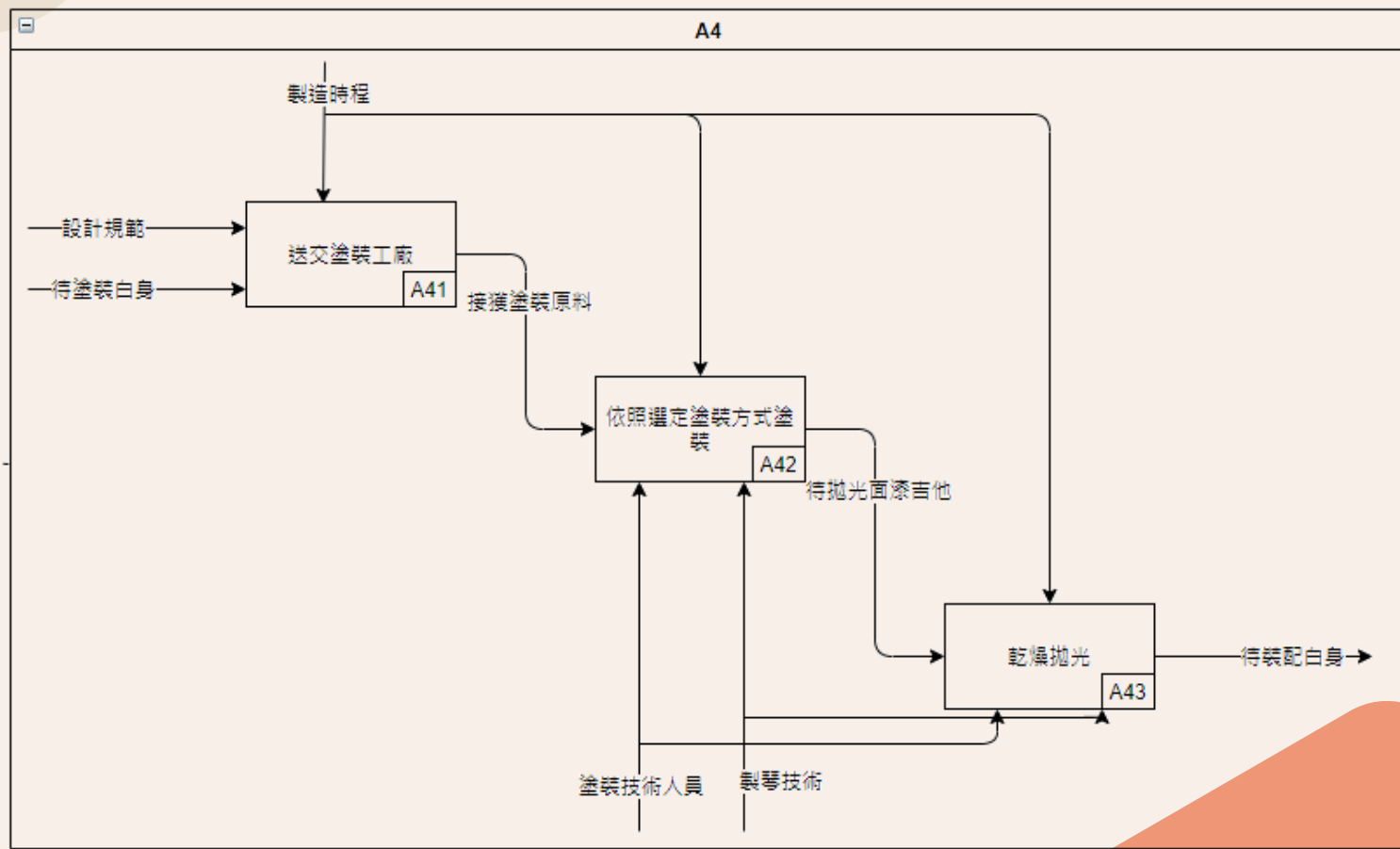

To-Be_目標模型假設



單位

時間以小時
為單位

1

2

訂單確認

為平均1小時的常態
分配



備料/挑料

平均12小時的
常態分配

3

4

鑲嵌與接合柄桶

為平均二天的
常態分配



乾燥膠合作業

為平均三天
的常態分配

5

6

噴漆拋光作業

為平均三天
的常態分配



To-Be_Flexsim

Throughput Per 150 Days

Object	Throughput
Order confirmation	60.00
Material preparation	60.00
Inlay preprocessing and Neck bolt on	59.50
Drying and Glueing	49.50
Finish and Polish	49.00

Utilization

■ Idle ■ Processing

Order confirmation

Material preparation

Inlay preprocessing and Neck bolt on

Drying and Glueing

Finish and Polish

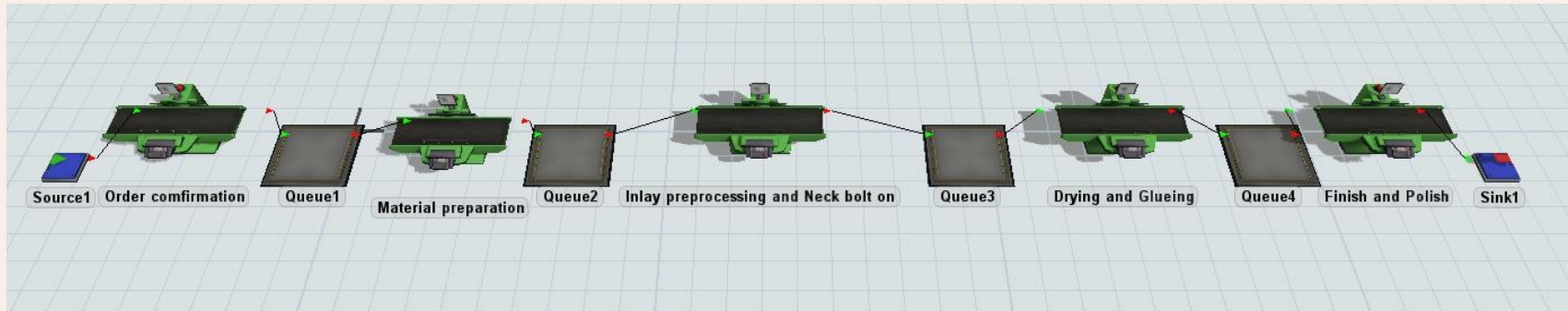
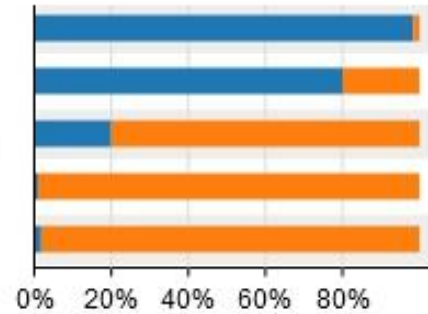

03

網站及APP Demo

網站架構圖

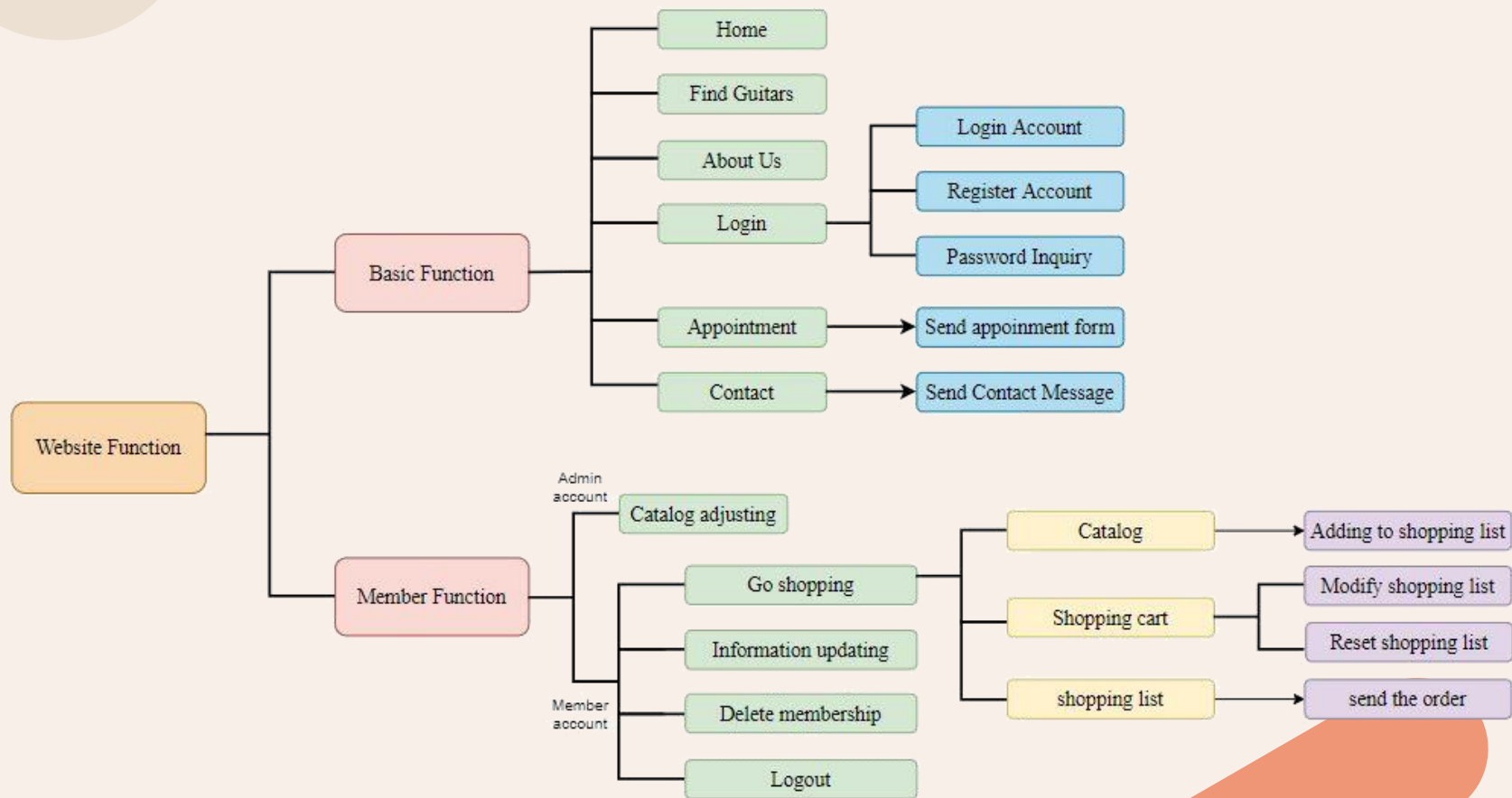

ER Model

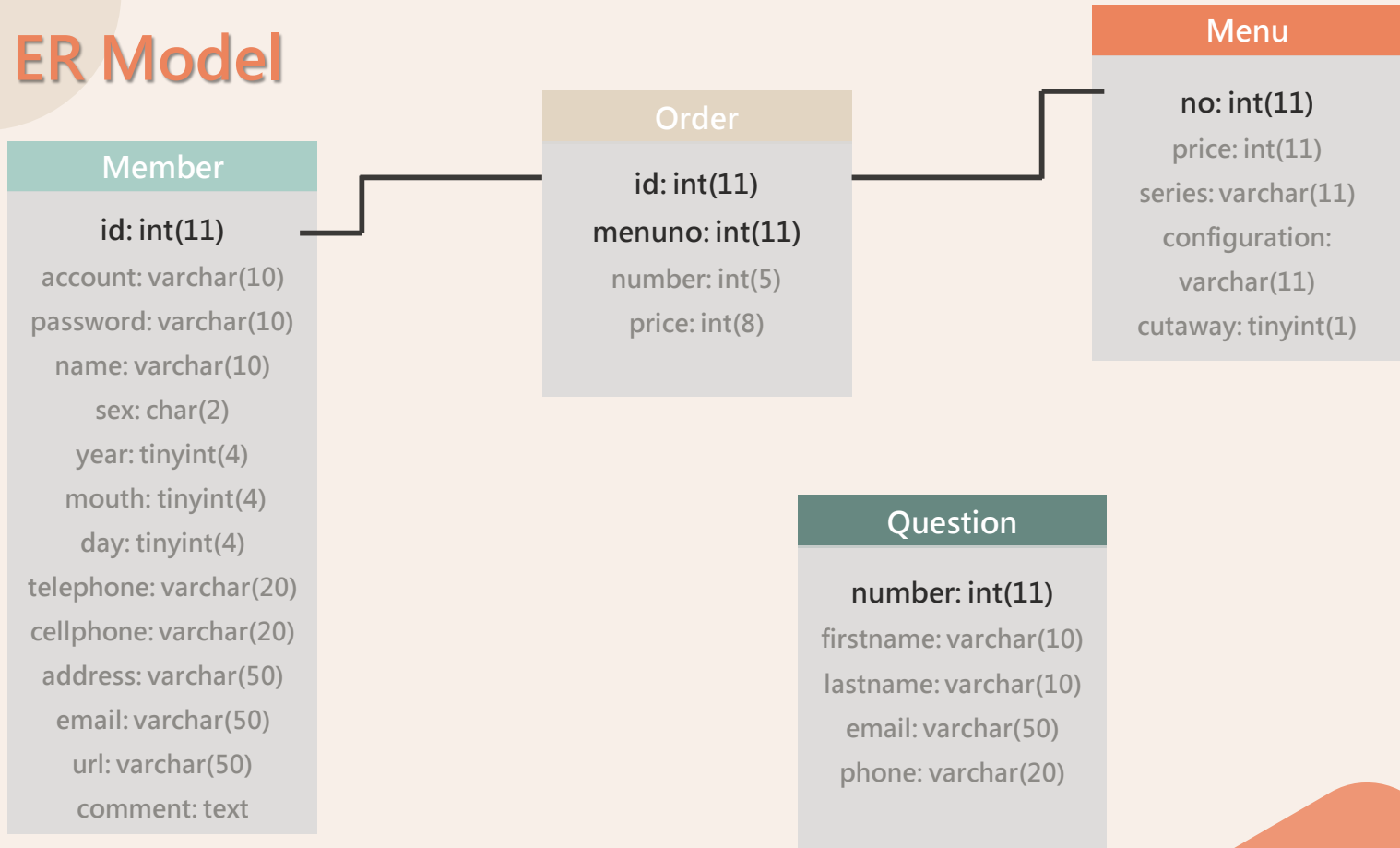

Website Demo

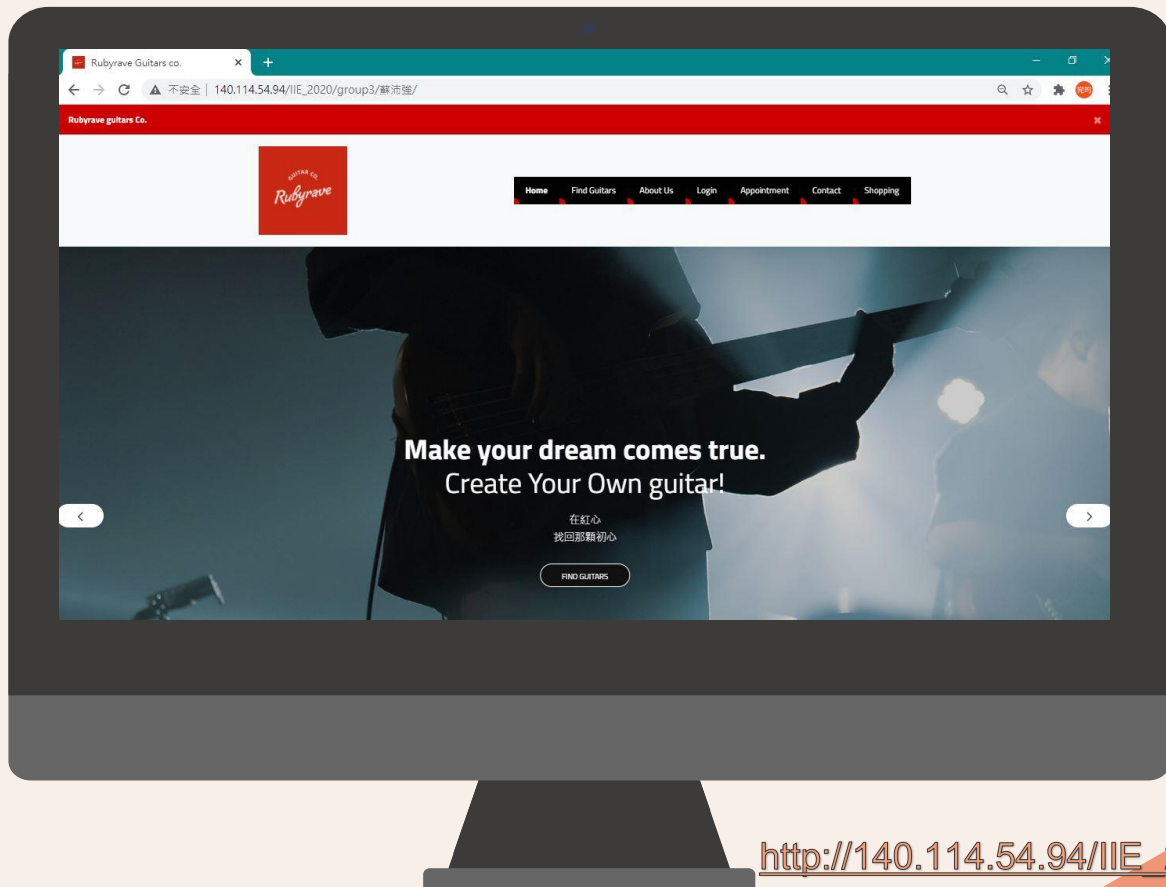

Chatbot & APP Demo

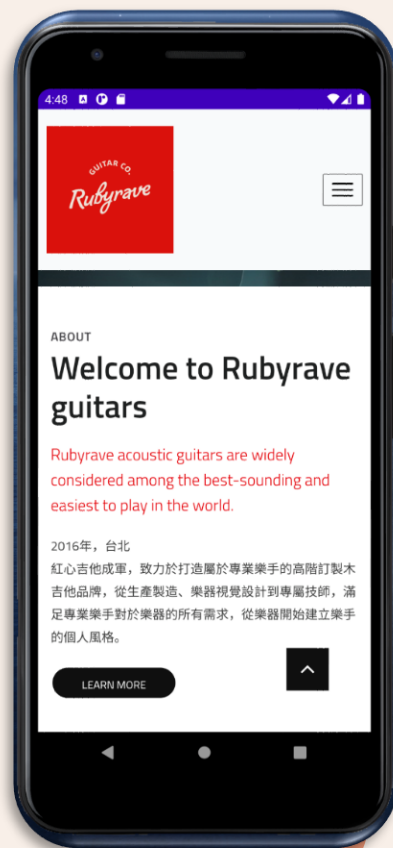
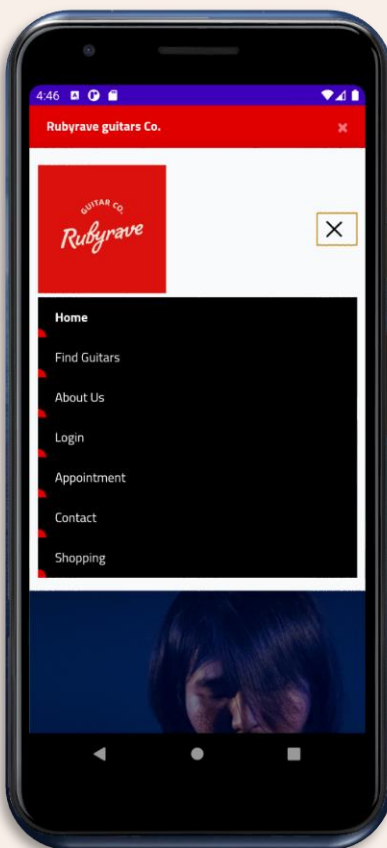
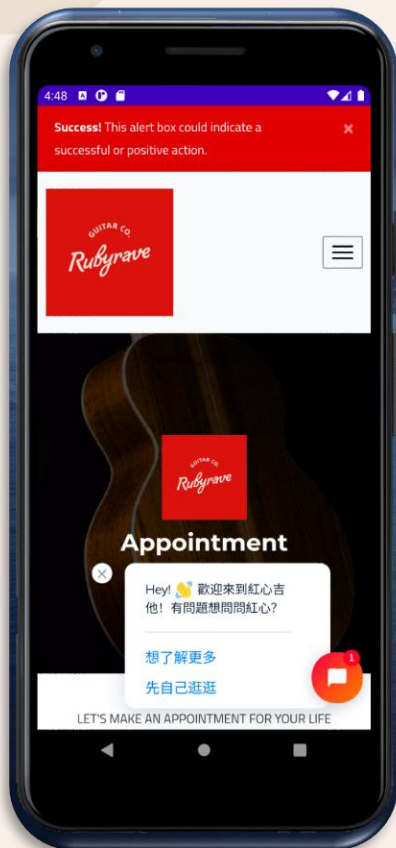

04

成果結論及
未來展望

KEY PARTNERS

木料供應商
拋光代工廠
貝殼螺鈕工廠
弦紐供應商
網域伺服器服務商
各區總代理
專業樂手

KEY ACTIVITIES

擁有快速模組訂製吉他的產線，能少量多樣訂製吉他

KEY RESOURCES

擁有製作吉他的技術
擁有配合良好的供應商

VALUE PROPOSITION

為顧客提供客製化吉他的服務
滿足顧客多樣化需求

CUSTOMER RELATIONSHIPS

透過線上平台去中間化，直接銷售
提供個人化訂製
提供客戶多種視覺風格選搭

CHANNELS

網路行銷
意見領袖曝光
官方線上平台

CUSTOMER SEGMENTS

獨立樂手
對於吉他品質有要求的顧客
想要擁有客製化吉他的樂手

COST STRUCTURE

吉他製作原料成本
官方網站維運成本
製作吉他人力成本

REVENUE STREAMS

線上模組訂製吉他
現下店面選購訂製
現下店面選購現貨新品

結論

改善

1. 生產效率提高
2. 顧客等候時間縮短
3. 作業流程簡化
4. 成本降低

未來展望

1. 與音樂頻道合作行銷
提高品牌曝光度
2. 與音樂教室、學校吉
他社團合作，打開新市
場

限制

1. 改善流程，無法加強
購買意願
2. 客製化吉他市場顧客
有限



**THANKS
FOR
LISTENING!**